

10 TPD Waste to Energy Chemical Plant

Energy efficiencies

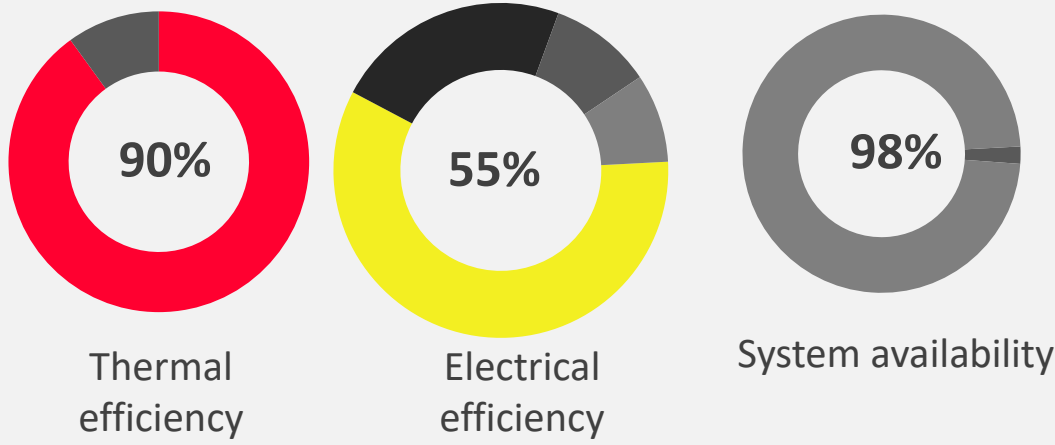

Life cycle assessment in comparison to incineration

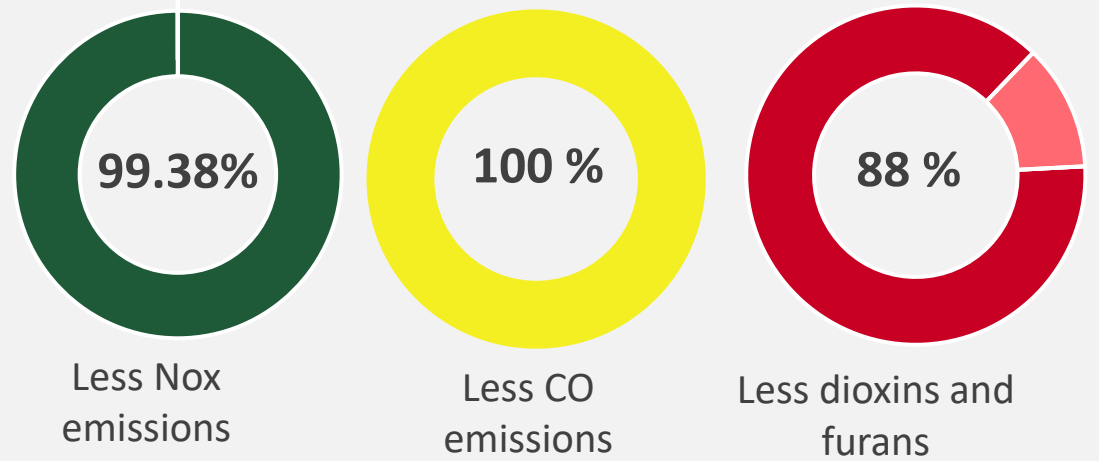

18 % more power than incineration facilities
Power 1000 houses annually



Only 10 personnel required for DCS monitoring and maintenance
PID control and interlock safety systems for process control

Operating modes

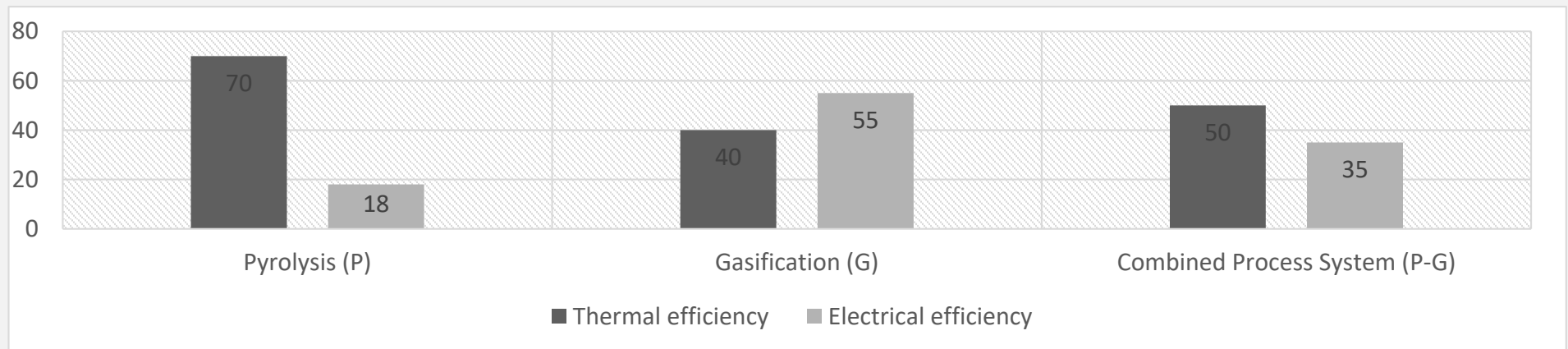

Process design

1 MSW Pre-Treatment

MSW shredder and metal removal

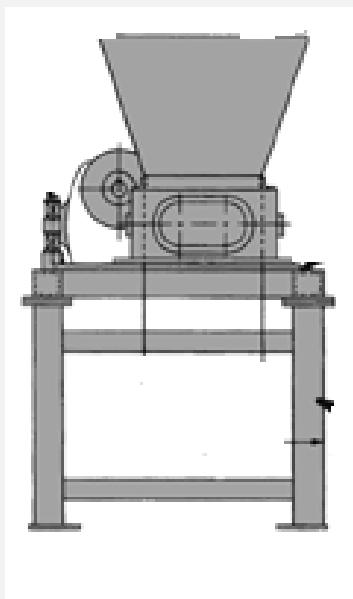

2 Plasma Gasifier

RF thermal plasma converts MSW to syngas



3 Syngas Purification and Electricity Generation

RF thermal plasma converts MSW to syngas

